

RECOMMENDED PCB LAYOUT
GENERAL TOLERANCE ±0.05

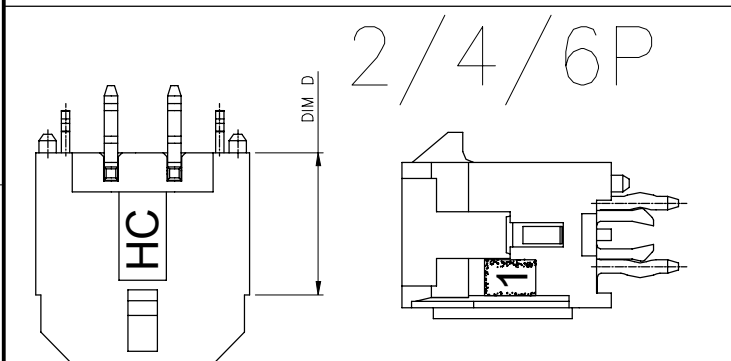
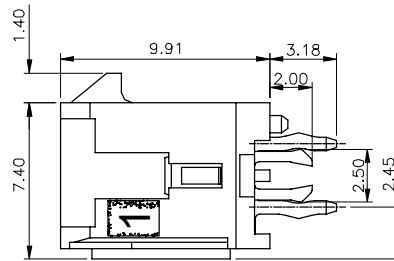
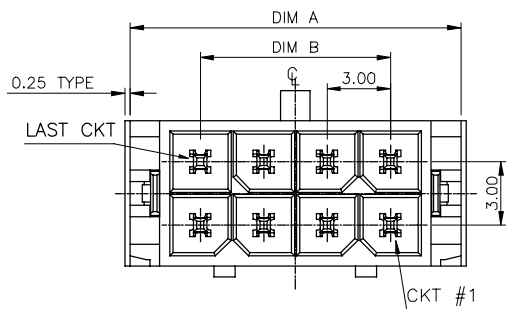
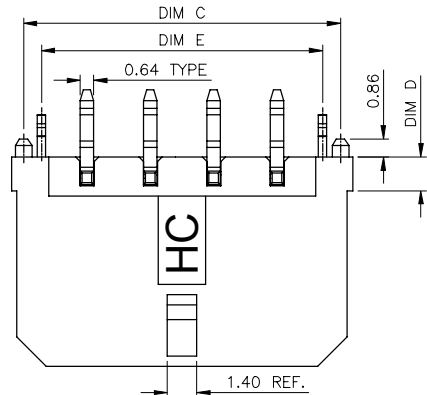

NOTES:

- MATERIAL:
 - HOUSING: THERMOPLASTIC, HIGH TEMP., UL94V-0; COLOR:BLACK.
 - CONTACT: HIGH CONDUCTIVITY COPPER ALLOY
- FINISH:
 - CONTACT:
 - 50u" MIN NICKEL UNDERPLATING OVERALL.
 - 60U" MIN MATTE TIN OVERALL.
- REFLOW SOLDER CAPABLE TO 260°C PER ACES SPEC.
- SPEC. PLS. REFER TO PS-57980-XXXXX-XXX
- PACKAGE PLS. REFER TO 57959-XXXXX-XX-TRP
- PART NUMBER

NO OF CKT X X-XXX 001:WITH KINK

PACKING PLATING
 0:TAPE & REEL N: MATTE TIN
 7:TAPE & REEL WITH COVER

CKT	DIM A	DIM B	DIM C	DIM D	DIM E
2	6.65	NA	6.00	6.74	4.30
4	9.65	3.00	9.00		7.30
6	12.65	6.00	12.00	1.60	10.30
8	15.65	9.00	15.00		13.30
10	18.65	12.00	18.00		16.30
12	21.65	15.00	21.00		19.30
14	24.65	18.00	24.00		22.30
16	27.65	21.00	27.00		25.30
18	30.65	24.00	30.00		28.30
20	33.65	27.00	33.00		31.30
22	36.65	30.00	36.00	34.30	
24	39.65	33.00	39.00	37.30	

QUALITY SYMBOLS MAJOR Ⓢ CRITICAL Ⓢ GENERAL TOLERANCES (UNLESS SPECIFIED) X. ±0.5 X ±0.36 .XX ±0.25 .XXX ±0.15 ANGLES ±2°	DRAWN BY Ding,shuqin DATE 23/12/13	 ACES ELECTRONICS TITLE 3.0mm PITCH HEADER CONN. T/H D/R S/T TYPE
	CHECKED BY Lu,ling Quan DATE 23/12/13	
	APPROVED BY hsieh, fu yu DATE 23/12/13	
	UNITS mm SCALE 4:1	

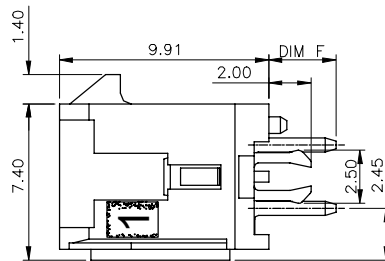
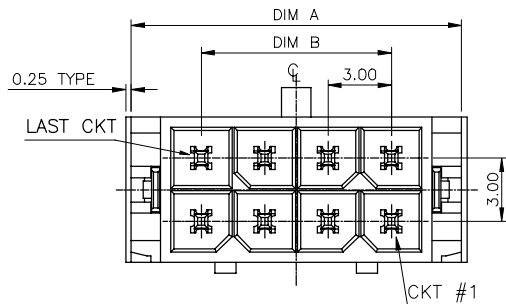
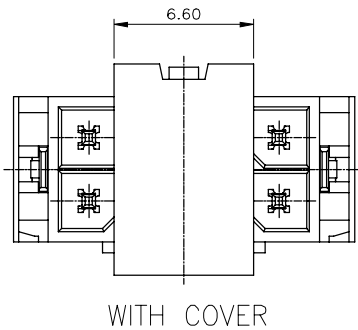
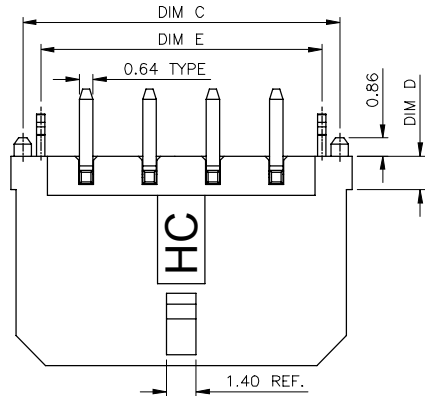
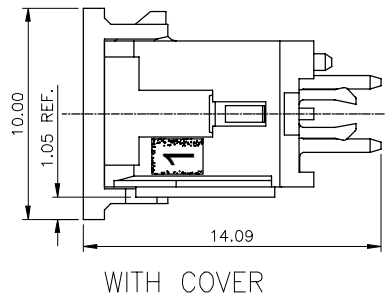
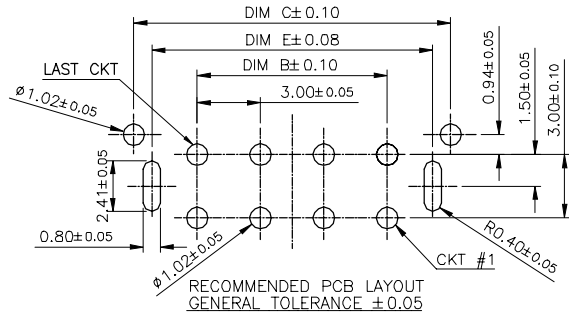

NOTES:

- MATERIAL:
 - HOUSING: THERMOPLASTIC, HIGH TEMP., UL94V-0; COLOR:BLACK.
 - CONTACT: HIGH CONDUCTIVITY COPPER ALLOY
- FINISH:
 - CONTACT:
 - 50u" MIN NICKEL UNDERPLATING OVERALL.
 - 60u" MIN MATTE TIN OVERALL.
 - 30u" MIN SELECT GOLD IN CONTACT AREA;
 - 100u" MIN MATTE TIN ON SOLDER TAILS OVER;
- REFLOW SOLDER CAPABLE TO 260°C PER ACES SPEC.
- SPEC. PLS. REFER TO PS-57980-XXXX-XXX
- PACKAGE PLS. REFER TO 57959-XXXX-XX-TRP
- PART NUMBER

56966-XXX	X	X-XXX	XXX	WITH KINK OR WITHOUT KINK	DIM F
NO OF CKT			002	WITHOUT KINK	3.18
			004	WITHOUT KINK	2.10
			005	WITHOUT KINK	2.60
			007	WITHOUT KINK	2.10

PACKING _____ PLATING _____
 0:TAPE & REEL N: MATTE TIN
 2:TRAY D: 30u" GOLD
 7:TAPE & REEL WITH COVER

CKT	DIM A	DIM B	DIM C	DIM D	DIM E
2	6.65	NA	6.00	6.74	4.30
4	9.65	3.00	9.00		7.30
6	12.65	6.00	12.00	1.60	10.30
8	15.65	9.00	15.00		13.30
10	18.65	12.00	18.00		16.30
12	21.65	15.00	21.00		19.30
14	24.65	18.00	24.00		22.30
16	27.65	21.00	27.00		25.30
18	30.65	24.00	30.00		28.30
20	33.65	27.00	33.00		31.30
22	36.65	30.00	36.00		34.30
24	39.65	33.00	39.00		37.30

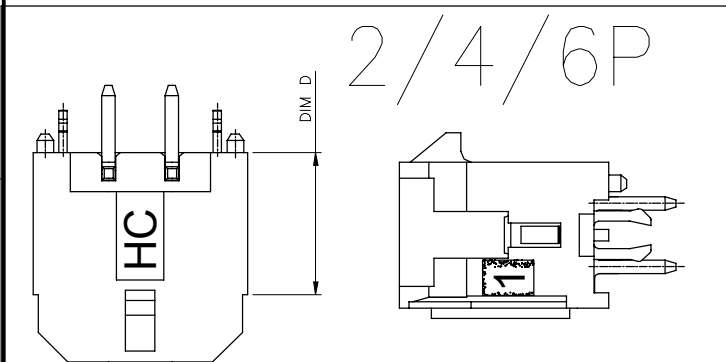

QUALITY SYMBOLS MAJOR Ⓢ CRITICAL Ⓢ GENERAL TOLERANCES (UNLESS SPECIFIED) X. ±0.5 X ±0.36 .XX ±0.25 .XXX ±0.15 ANGLES ±2°	DRAWN BY Ding,shuqin DATE 23/12/13	 ACES ELECTRONICS TITLE 3.0mm PITCH HEADER CONN. T/H/D/R/S/T TYPE
	CHECKED BY Lu,ling Quan DATE 23/12/13	
UNITS mm		SIZE A4
SCALE 4:1	SHEET NO. 2 OF 3	REV H
RFG NO. N/A		DWG NO. 56966-XXXX-XXX

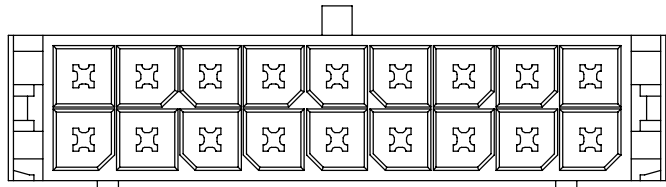

18-CKT

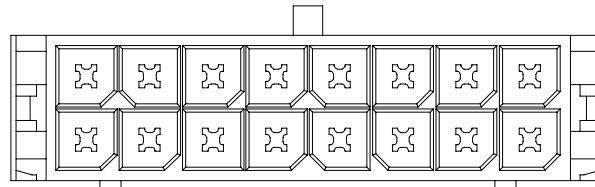

16-CKT

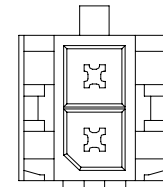

2-CKT

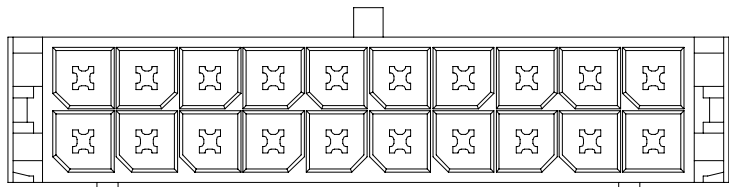

20-CKT

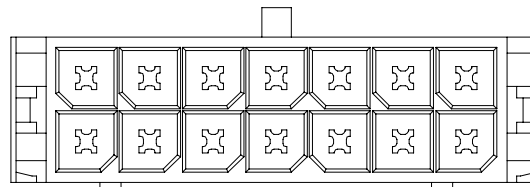

14-CKT

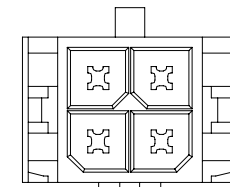

4-CKT

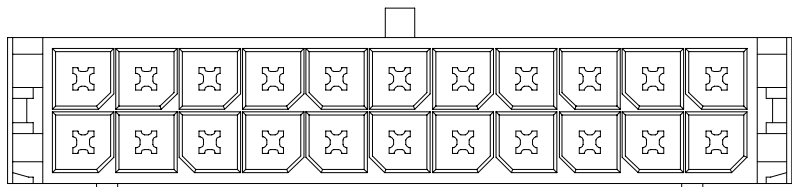

22-CKT

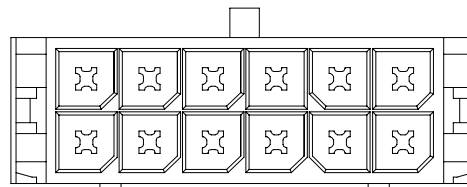

12-CKT

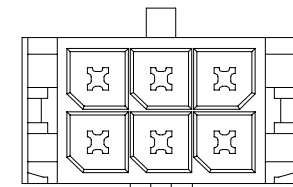

6-CKT

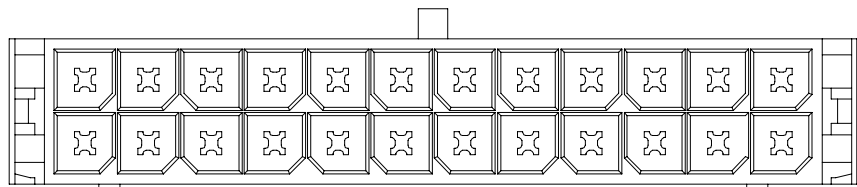

24-CKT

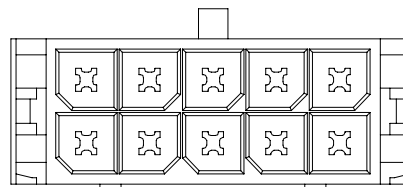

10-CKT

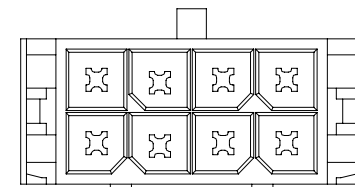

8-CKT

QUALITY SYMBOLS

- MAJOR
- CRITICAL

GENERAL TOLERANCES
(UNLESS SPECIFIED)

- X. ±0.5
- X ±0.36
- .XX ±0.25
- .XXX ±0.15
- ANGLES ±2°

DRAWN BY

Ding,shuqin

DATE

23/12/13

CHECKED BY

Lu,ling Quan

DATE

23/12/13

APPROVED BY

hsieh, fu yu

DATE

23/12/13



3.0mm PITCH HEADER CONN.
T/H D/R S/T TYPE

UNITS
mm



SIZE
A4

RFQ NO.

N/A

SCALE
4 : 1

SHEET NO.
3 OF 3

REV

DWG NO.

56966-XXXXX-XXX